

AEROEVAPORATORI A SOFFITTO
Ceiling unit coolers



RIVACOLD

Tabella / Table

(A)	RSI1250 RSI1250ED
(B)	RSI2250 RSI2250ED
(C)	RSI3250 RSI3250ED
(D)	RSI4250 RSI4250ED



Tabella / Table

(A)	RSI23503 RSI23503ED RSI23507 RSI23507ED
(B)	RSI33503 RSI33503ED RSI33507 RSI33507ED
(C)	RSI43503 RSI43503ED RSI43507 RSI43507ED



Aeroevaporatori a soffitto RSI

RSI Ceiling unit coolers

Caratteristiche generali

Gli aeroevaporatori della serie RSI sono stati ideati per essere installati in celle frigorifere per la conservazione di prodotti freschi e congelati.

Questa gamma presenta il vantaggio di avere una forma particolarmente compatta pur mantenendo una resa comparabile a quella della gamma esistente RC, consentendo applicazioni con un minimo ingombro in altezza all'interno della cella.

La gamma RSI è disponibile con due differenti diametri di ventola e tre diversi passi alette a seconda dell'applicazione richiesta. Inoltre i modelli aventi diametro da 250mm sono realizzati con geometria 25 x 21,65 e tubo da 3/8", mentre quelli con diametro da 350mm hanno una geometria 37,5 x 32,5 e tubo da 12 mm. La versione ED, fornita con resistenze di sbrinamento già montate, è adatta per essere utilizzata alle basse temperature.

General features

RSI range unit coolers have been designed to be installed inside cold rooms suited for fresh and frozen goods storage.

This range has the advantage of having extremely compact dimensions and at the same time gives capacities comparable to the RC range. This feature allows applications inside cold rooms with a minimum encumbrance in height.

RSI range is available in two different fan diameters and three types of fin spacing according to the needed application.

Furthermore, the models having 250mm fan diameter are made with a geometry of 25 x 21,65 and 3/8" tube, whereas those having 350mm fan diameter are made with a geometry of

37,5 x 32,5 and 12 mm tube. The ED version is supplied with mounted defrosting heaters and is suitable for being used at low temperature applications.

Optional - Optional items

- Batteria verniciata
Varnished coil
- Resistenza per il tubo di scarico
Drainage pipe heater



Caratteristiche costruttive

Manufacturing features

RIVACOLD

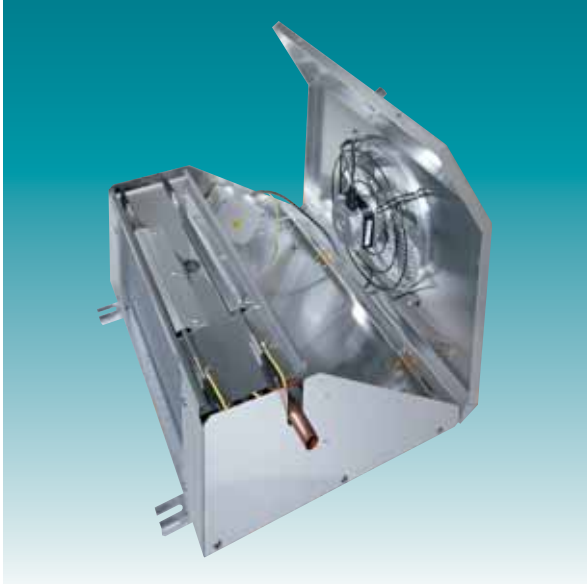

Mod. RSI.250.. con resistenza montata e cablata su scatola di derivazione.

RSI.250.. model with defrosting heater mounted and wired on the unit cooler's terminal box.



Mod. RSI.250..: lato collegamento frigorifero.

RSI.250.. model: pipe connection side.

Mod. RSI.350..: lato collegamento elettrico.

RSI.350.. model: electrical connection side.



Mod. RSI.350..: lato collegamento frigorifero.

RSI.350.. model: pipe connection side.



Mod. RSI.350.. con controgocciolatoio e resistenza di sbrinamento.

RSI.350.. model with drip tray and defrosting heater.

Manufacturing features

Batteria

La gamma é costituita da due tipi di batterie costruite con alette in alluminio e tubo in rame: tubo da 3/8" con geometria 25 x 21,65, per modelli con ventole di diametro da 250 mm; tubo da 12 mm con geometria 37,5 x 32,5 per i modelli con ventole da 350 mm.

I modelli con diametro ventola 250 mm hanno una batteria con passo alette 5,3 mm adatto per applicazioni di temperatura cella (Tc) da -30°C a +10°C.

I modelli con diametro ventole 350 mm si suddividono a loro volta in due gruppi : modelli con passo alette da 3,5 mm adatti per applicazioni di temperatura cella (Tc) da -5°C a +12°C; modelli con passo alette 7 mm adatti per applicazioni di temperatura cella (Tc) da -35°C a +4°C.

La batteria viene collaudata con azoto ad una pressione di 25 bar.

Motoventilatori

I motoventilatori utilizzati hanno le seguenti caratteristiche:

- costruiti nel rispetto delle norme EN 60335-1, con protezione termica interna
- alimentazione 230-240V/1/50-60Hz
- diametro ventola da 250mm
 - grado di protezione IP42
 - classe di isolamento B
 - temperatura di funzionamento da -40°C a +40°C
- diametro ventola da 350mm
 - grado di protezione IP44
 - classe di isolamento B
 - temperatura di funzionamento da -40°C a +35°C
- esecuzione elettrica conforme alla direttiva 73/23 CEE Bassa Tensione

Carenatura

È realizzata in alluminio. Le soluzioni costruttive adottate conferiscono robustezza alla carenatura e garantiscono l'assenza di vibrazioni durante il funzionamento. Le viti, le rondelle e i dadi sono di acciaio inossidabile.

Coil

The range consist of two types of coils, both made of aluminium fins and copper tube: 3/8" tube with a geometry of 25 x 21,65, for models with 250 mm fan diameter; 12 mm tube with a geometry of 37,5 x 32,5, for models with 350 mm fan diameter.

The model types having 250 mm fan diameter are fitted with a coil of 5,3 mm fin spacing, suited for applications with a cold room temperature (Tc) from -30°C to +10°C.

The model types having 350 mm fan diameter are made of two different groups: models with 3,5 mm fin spacing suited for cold room temperature (Tc) from -5°C to +12°C; models with 7 mm fin spacing suited for cold room temperature (Tc) from -35°C to +4°C.

The coils are tested with nitrogen at a pressure of 25 bar.

Fan motors

The fan motor models in use have the following features:

- manufactured following EN 60335-1 laws, with internal thermal protection
- power supply 230-240V/1/50-60Hz
- fan diameter 250 mm
 - IP42 protection rate
 - B insulation class
 - operating temperature from -40°C to + 40°C
- fan diameter 350 mm
 - IP44 protection rate
 - B insulation class
 - operating temperature from -40°C to +35°C
- electrics made in conformity with 73/23 CEE Low Tension directive

Housing

The housing is made of aluminium. The manufacturing solutions used give the housing strength and guarantee the absence of vibrations during the functioning. Screws, washers and nuts are made of stainless steel.



Manufacturing features

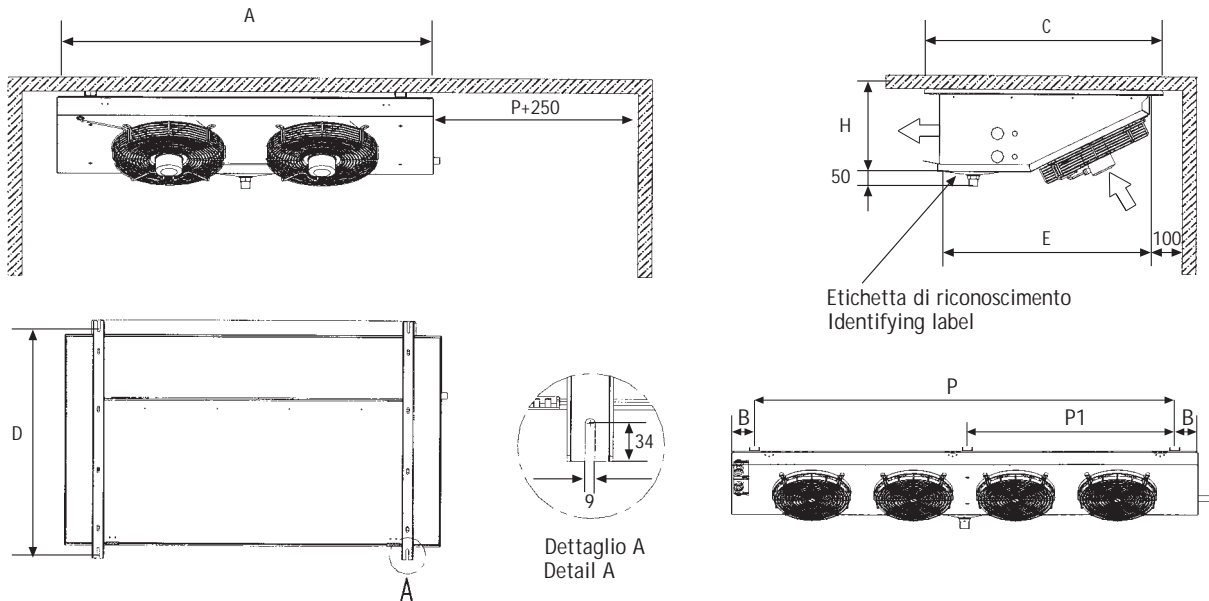

Serie RSI / RSI Range

Modello Model	RSI	1250-1250ED	2250-2250ED	3250-3250ED	4250-4250ED
Dimensioni Dimensions (mm)	A	565	935	1305	1675
	P	400	770	1140	1510
	P1	---	---	---	745
	B	82,5	82,5	82,5	82,5
	C	550	550	550	550
	D	483	483	483	483
	E	461	461	461	461
	H	241	241	241	241
Attacchi Connections	ø ingresso - ø inlet	12 x 1mm	12 x 1mm	12 x 1mm	12 x 1mm
	ø uscita - ø outlet	16 x 1mm	16 x 1mm	22 x 1mm	22 x 1mm
	ø scarico - ø drain	1/2" Gas(20mm)	1/2" Gas(20mm)	1" Gas(33mm)	1" Gas(33mm)

Serie RSI / RSI Range

Modello Model	RSI	23503-23503ED 23507-23507ED	33503-33503ED 33507-33507ED	43503-43503ED 43507-43507ED
Dimensioni Dimensions (mm)	A	1300	1750	2200
	P	1070	1520	1970
	P1	---	510	985
	B	115	115	115
	C	820	820	820
	D	753	753	753
	E	726	726	726
	H	287	287	287
Attacchi Connections	ø ingresso - ø inlet	12 x 1mm - 1/2"SAE	12 x 1mm - 1/2"SAE	12 x 1mm - 1/2"SAE
	ø uscita - ø outlet	22 x 1mm	28 x 1,5mm	28 x 1,5mm
	ø scarico - ø drain	1"Gas(33mm)	1"Gas(33mm)	1"Gas(33mm)

Technical features

Serie RSI / RSI Range

5,3 mm Passo alette / Fin spacing (Ø250)

Modello Model	RSI	1250 1250ED	2250 2250ED	3250 3250ED	4250 4250ED	
Capacità ΔT 10 T. cella 2°C Capacity ΔT 10 Room T. 2°C	kW	1,28	2,53	3,85	4,97	
Portata d'aria Air flow	m ³ /h	583,0	1137,5	1706,3	2275,0	
Freccia d'aria Air throw	m	6,5	7,0	8,5	9,5	
Superficie totale Total surface	m ²	3,73	7,36	11,00	14,60	
Volume circuito evaporatore Unit cooler volume circuit	dm ³	1,2	2,26	3,18	4,19	
Motoventilatori Fan motors	n x Ømm	1x250	2x250	3x250	4x250	
Assorbimento motori (*) Motor power consumption	A	0,45	0,90	1,35	1,80	
	W	65	130	195	260	
Sbrinamento elettrico (*) Electrical defrost	W	500	900	1300	1800	
Peso netto Net weight	vers. standard standard vers.	kg	9,0	17,0	20,5	26,0
	vers. ED ED vers.	kg	9,5	18,0	22,0	28,0

(*) Alimentazione elettrica: motoventilatori 230V-1-50Hz, sbrinamento elettrico predisposto per 400-3-50Hz
Power supply : fan motors (230V-1-50Hz), electrical defrost preset for 400V/3/50Hz

Serie RSI / RSI Range

3,5 mm Passo alette / Fin spacing (Ø350)

Modello Model	RSI	23503 23503ED	33503 33503ED	43503 43503ED	
Capacità ΔT 10 T. cella 2°C Capacity ΔT 10 Room T. 2°C	kW	5,75	8,25	11,05	
Portata d'aria Air flow	m ³ /h	2391,0	3459,0	4612,5	
Freccia d'aria Air throw	m	10,0	11,0	12,0	
Superficie totale Total surface	m ²	24,70	34,50	46,00	
Peso netto Net weight	vers. standard standard vers.	kg	35,9	49,5	60,2
	vers. ED ED vers.	kg	38,4	53	64,7

Serie RSI / RSI Range

7 mm Passo alette / Fin spacing (Ø350)

Modello Model	RSI	23507 23507ED	33507 33507ED	43507 43507ED	
Capacità ΔT 10 T. cella -20°C Capacity ΔT 10 Room T. -20°C	kW	4,13	5,78	7,96	
Portata d'aria Air flow	m ³ /h	3150,0	4598,0	5962,5	
Freccia d'aria Air throw	m	12,0	12,5	13,0	
Superficie totale Total surface	m ²	13,20	18,80	24,40	
Peso netto Net weight	vers. standard standard vers.	kg	34,9	48	58,2
	vers. ED ED vers.	kg	37,4	51,5	62,7

Technical features

Serie RSI / RSI Range		7 - 3,5 mm Passo alette / Fin spacing (Ø350)		
Modello Model	RSI	23503 23503ED 23507 23507ED	33503 33503ED 33507 33507ED	43503 43503ED 43507 43507ED
Volume circuito evaporatore Unit cooler volume circuit	dm ³	4,88	6,86	8,83
Motoventilatori Fan motors	n x Ømm	2x350	3x350	4x350
Assorbimento motori (*) Motor power consumption	A	1,16	1,74	2,32
	W	260	390	520
Sbrinamento elettrico (*) Electrical defrost	W	2800	4096	5360

(*) Alimentazione elettrica: motoventilatori 230V-1-50Hz, sbrinamento elettrico predisposto per 400-3-50Hz
Power supply : fan motors (230V-1-50Hz), electrical defrost preset for 400V/3/50Hz

Scelta evaporatore

Model choice

Per una corretta scelta dell'evaporatore, utilizzare le tabelle "potenza frigorifera".
Nelle tabelle vengono riportate le rese frigorifere calcolate per un range di temperatura cella (Tc) che varia in funzione del diametro ventola e del passo alette della macchina.
Per ogni passo alette si consiglia la seguente applicazione: passo alette 3,5mm, utilizzo ad una Tc ≥ +2°C; passo alette 5,3mm, utilizzo ad una Tc ≥ -30°C; passo alette 7mm utilizzo ad una Tc ≥ -35°C. Inoltre tali rese vengono calcolate in funzione di un ΔT (differenza tra la temperatura dell'aria in entrata e la temperatura di evaporazione del refrigerante) che va da 5°C a 10°C, utilizzando come refrigerante il gas R404A.
Impiegando altri refrigeranti, la capacità va moltiplicata per il fattore correttivo di seguito riportato: R22=0,93 ; R134a=0,91; R507/R404A=1.
I parametri per la scelta dell'evaporatore sono: la temperatura della cella, il valore ΔT ed il carico termico. Nella colonna corrispondente alla temperatura cella desiderata, sceglieremo il modello che in corrispondenza del ΔT richiesto, avrà una resa uguale o superiore al carico termico.

For a correct choice of the unit cooler, use the "refrigerating output" tables.
In these tables are quoted the refrigerating capacities calculated for a cold room temperature (Tc) that changes according to the fan diameter and fin spacing of the unit cooler. For each different type of fin spacing we recommend to use the following applications: 3,5mm fin spacing, Tc ≥ +2°C; 5,3mm fin spacing, Tc ≥ -30°C; 7mm fin spacing, Tc ≥ -35°C.
Those capacities are calculated on the base of a ΔT value (i.e. difference between the inlet air temperature and the gas evaporating temperature) from 5 to 10, by using R404A gas.
In case of a different gas in use, the capacity is to be multiplied by the relevant corrective factor: R22 = 0,93; R134a = 0,91; R507/R404A = 1.
The parameters valid for the unit cooler choice are the following ones: the cold room temperature, the ΔT value and the heat load.
In the column corresponding to the requested cold room temperature we will choose the model that, matching the line of the requested ΔT, will have a capacity equal or bigger than the heat load.

RSI1250 RSI1250ED

5,3 mm Passo alette / Fin spacing (Ø250)

Tc		-30°C	-25°C	-20°C	-15°C	-10°C	-5°C	0°C	2°C	4°C	6°C	8°C	10°C
ΔT 10	UR/RH 76% kW	1,01	1,05	1,09	1,12	1,15	1,20	1,27	1,28	1,29	1,30	1,31	1,33
ΔT 9	UR/RH 79% kW	0,90	0,94	0,97	1,00	1,02	1,07	1,13	1,14	1,15	1,16	1,18	1,20
ΔT 8	UR/RH 82% kW	0,79	0,82	0,84	0,87	0,89	0,93	0,99	1,00	1,01	1,02	1,03	1,05
ΔT 7	UR/RH 85% kW	0,68	0,70	0,72	0,73	0,76	0,79	0,84	0,85	0,86	0,87	0,88	0,90
ΔT 6	UR/RH 89% kW	0,57	0,58	0,59	0,60	0,63	0,66	0,71	0,72	0,73	0,74	0,75	0,77
ΔT 5	UR/RH 93% kW	0,44	0,45	0,46	0,47	0,49	0,52	0,56	0,57	0,57	0,58	0,60	0,62

RSI2250 RSI2250ED

5,3 mm Passo alette / Fin spacing (Ø250)

Tc		-30°C	-25°C	-20°C	-15°C	-10°C	-5°C	0°C	2°C	4°C	6°C	8°C	10°C
ΔT 10	UR/RH 76% kW	1,56	1,74	1,91	2,07	2,16	2,31	2,49	2,53	2,57	2,61	2,65	2,71
ΔT 9	UR/RH 79% kW	1,45	1,61	1,75	1,86	1,96	2,09	2,25	2,29	2,32	2,36	2,39	2,47
ΔT 8	UR/RH 82% kW	1,32	1,46	1,57	1,66	1,74	1,86	2,00	2,03	2,06	2,08	2,13	2,20
ΔT 7	UR/RH 85% kW	1,18	1,29	1,38	1,43	1,52	1,62	1,75	1,77	1,79	1,80	1,87	1,92
ΔT 6	UR/RH 89% kW	1,03	1,11	1,16	1,22	1,29	1,38	1,50	1,51	1,53	1,55	1,62	1,67
ΔT 5	UR/RH 93% kW	0,86	0,91	0,96	0,97	1,06	1,14	1,24	1,25	1,26	1,31	1,36	1,41

RSI3250 RSI3250ED

5,3 mm Passo alette / Fin spacing (Ø250)

Tc		-30°C	-25°C	-20°C	-15°C	-10°C	-5°C	0°C	2°C	4°C	6°C	8°C	10°C
ΔT 10	UR/RH 76% kW	2,56	2,82	3,04	3,19	3,34	3,54	3,79	3,85	3,90	3,96	4,01	4,09
ΔT 9	UR/RH 79% kW	2,36	2,57	2,75	2,88	3,00	3,19	3,41	3,47	3,51	3,55	3,59	3,71
ΔT 8	UR/RH 82% kW	2,13	2,31	2,45	2,52	2,66	2,82	3,03	3,07	3,10	3,13	3,18	3,30
ΔT 7	UR/RH 85% kW	1,89	2,02	2,11	2,19	2,30	2,44	2,63	2,65	2,67	2,69	2,79	2,86
ΔT 6	UR/RH 89% kW	1,62	1,72	1,78	1,85	1,95	2,08	2,24	2,26	2,30	2,35	2,40	2,48
ΔT 5	UR/RH 93% kW	1,33	1,39	1,43	1,50	1,59	1,70	1,85	1,88	1,91	1,94	2,01	2,08

RSI4250 RSI4250ED

5,3 mm Passo alette / Fin spacing (Ø250)

Tc		-30°C	-25°C	-20°C	-15°C	-10°C	-5°C	0°C	2°C	4°C	6°C	8°C	10°C
ΔT 10	UR/RH 76% kW	2,80	3,21	3,59	3,88	4,16	4,49	4,86	4,97	5,07	5,15	5,25	5,38
ΔT 9	UR/RH 79% kW	2,63	2,98	3,30	3,56	3,79	4,09	4,42	4,51	4,59	4,66	4,75	4,92
ΔT 8	UR/RH 82% kW	2,43	2,73	2,99	3,17	3,40	3,66	3,96	4,03	4,09	4,15	4,24	4,40
ΔT 7	UR/RH 85% kW	2,20	2,44	2,63	2,79	2,98	3,21	3,47	3,52	3,57	3,61	3,74	3,86
ΔT 6	UR/RH 89% kW	1,93	2,12	2,26	2,39	2,56	2,76	3,00	3,04	3,07	3,13	3,26	3,37
ΔT 5	UR/RH 93% kW	1,63	1,76	1,86	1,98	2,12	2,29	2,51	2,53	2,55	2,66	2,76	2,86

Tc = temperatura cella / cold room temperature

**R404A****Potenza frigorifera***Refrigerating output***RIVACOLD****RSI23503 RSI23503ED**

3,5 mm Passo alette / Fin spacing (Ø350)

Tc			-5°C (*)	0°C (*)	2°C	4°C	6°C	8°C	10°C	12°C
ΔT 10	UR/RH 76%	kW	5,35	5,69	5,75	5,79	5,84	5,87	5,97	6,13
ΔT 9	UR/RH 79%	kW	4,79	5,08	5,13	5,15	5,20	5,28	5,37	5,47
ΔT 8	UR/RH 82%	kW	4,21	4,46	4,48	4,53	4,58	4,63	4,69	4,77
ΔT 7	UR/RH 85%	kW	3,60	3,81	3,83	3,86	3,89	3,92	3,99	4,06
ΔT 6	UR/RH 89%	kW	3,00	3,18	3,21	3,24	3,27	3,30	3,37	3,44
ΔT 5	UR/RH 93%	kW	2,38	2,54	2,56	2,58	2,61	2,67	2,73	2,80

RSI33503 RSI33503ED

3,5 mm Passo alette / Fin spacing (Ø350)

Tc			-5°C (*)	0°C (*)	2°C	4°C	6°C	8°C	10°C	12°C
ΔT 10	UR/RH 76%	kW	7,63	8,15	8,25	8,33	8,41	8,46	8,61	8,84
ΔT 9	UR/RH 79%	kW	6,87	7,31	7,38	7,42	7,50	7,63	7,76	7,90
ΔT 8	UR/RH 82%	kW	6,05	6,43	6,50	6,57	6,64	6,72	6,80	6,93
ΔT 7	UR/RH 85%	kW	5,19	5,51	5,55	5,60	5,65	5,70	5,80	5,91
ΔT 6	UR/RH 89%	kW	4,34	4,62	4,66	4,71	4,76	4,81	4,91	5,01
ΔT 5	UR/RH 93%	kW	3,47	3,70	3,73	3,77	3,81	3,90	4,00	4,10

RSI43503 RSI43503ED

3,5 mm Passo alette / Fin spacing (Ø350)

Tc			-5°C (*)	0°C (*)	2°C	4°C	6°C	8°C	10°C	12°C
ΔT 10	UR/RH 76%	kW	10,40	11,00	11,05	11,10	11,20	11,30	11,40	11,60
ΔT 9	UR/RH 79%	kW	9,24	9,75	9,80	9,90	10,00	10,10	10,20	10,30
ΔT 8	UR/RH 82%	kW	8,06	8,51	8,58	8,65	8,72	8,79	8,86	9,01
ΔT 7	UR/RH 85%	kW	6,72	7,08	7,12	7,16	7,20	7,24	7,35	7,48
ΔT 6	UR/RH 89%	kW	5,56	5,88	5,92	5,97	6,02	6,07	6,19	6,31
ΔT 5	UR/RH 93%	kW	4,39	4,67	4,70	4,73	4,77	4,88	4,99	5,11

Tc = temperatura cella / cold room temperature

(*) Per modelli passo alette 3,5 mm, si consiglia un utilizzo ad una Tc ± +2°C - For 3,5 mm fin spacing models we recommend to use the application Tc ± +2°C

Refrigerating output
RSI23507 RSI23507ED

7 mm Passo alette / Fin spacing (Ø350)

Tc		-35°C	-30°C	-25°C	-20°C	-15°C	-10°C	-5°C	0°C	2°C	4°C
ΔT 10	UR/RH 76% kW	2,97	3,39	3,79	4,13	4,31	4,56	4,80	5,06	5,10	5,13
ΔT 9	UR/RH 79% kW	2,76	3,12	3,45	3,69	3,87	4,07	4,28	4,51	4,54	4,58
ΔT 8	UR/RH 82% kW	2,52	2,82	3,08	3,26	3,40	3,57	3,75	3,94	3,97	4,00
ΔT 7	UR/RH 85% kW	2,24	2,48	2,65	2,77	2,91	3,04	3,19	3,36	3,37	3,39
ΔT 6	UR/RH 89% kW	1,93	2,11	2,23	2,31	2,42	2,53	2,65	2,80	2,81	2,83
ΔT 5	UR/RH 93% kW	1,58	1,68	1,75	1,83	1,91	1,99	2,10	2,23	2,24	2,26

RSI33507 RSI33507ED

7 mm Passo alette / Fin spacing (Ø350)

Tc		-35°C	-30°C	-25°C	-20°C	-15°C	-10°C	-5°C	0°C	2°C	4°C
ΔT 10	UR/RH 76% kW	4,08	4,70	5,28	5,78	6,23	6,54	6,91	7,32	7,38	7,42
ΔT 9	UR/RH 79% kW	3,80	4,34	4,83	5,24	5,61	5,86	6,18	6,54	6,57	6,60
ΔT 8	UR/RH 82% kW	3,49	3,94	4,33	4,66	4,95	5,08	5,34	5,64	5,69	5,74
ΔT 7	UR/RH 85% kW	3,12	3,48	3,79	4,04	4,20	4,35	4,56	4,81	4,84	4,87
ΔT 6	UR/RH 89% kW	2,70	2,97	3,19	3,39	3,51	3,62	3,81	4,03	4,06	4,09
ΔT 5	UR/RH 93% kW	2,22	2,41	2,56	2,66	2,74	2,87	3,03	3,22	3,25	3,28

RSI43507 RSI43507ED

7 mm Passo alette / Fin spacing (Ø350)

Tc		-35°C	-30°C	-25°C	-20°C	-15°C	-10°C	-5°C	0°C	2°C	4°C
ΔT 10	UR/RH 76% kW	6,05	6,82	7,51	7,96	8,31	8,72	9,13	9,58	9,63	9,66
ΔT 9	UR/RH 79% kW	5,59	6,23	6,79	7,15	7,42	7,75	8,11	8,51	8,56	8,61
ΔT 8	UR/RH 82% kW	5,05	5,58	6,02	6,29	6,48	6,76	7,06	7,41	7,45	7,49
ΔT 7	UR/RH 85% kW	4,46	4,87	5,12	5,38	5,52	5,73	5,99	6,27	6,29	6,32
ΔT 6	UR/RH 89% kW	3,80	4,08	4,27	4,38	4,55	4,73	4,94	5,21	5,24	5,27
ΔT 5	UR/RH 93% kW	3,07	3,21	3,32	3,44	3,56	3,71	3,90	4,13	4,15	4,18

Tc = temperatura cella / cold room temperature



Dimensioni imballi

Packages dimensions



Codice Code	Dimensione imballo evaporatore Evaporator package dimensions			
	A mm	B mm	H mm	Peso Weight Kg
RSI1250 . .	660	550	300	3,0
RSI2250 . .	1030	550	300	4,0
RSI3250 . .	1400	550	300	5,0
RSI4250 . .	1770	550	300	6,0
RSI2350 . . .	1400	970	420	12,6
RSI3350 . . .	1850	970	420	16,8
RSI4350 . . .	2300	970	420	18,8

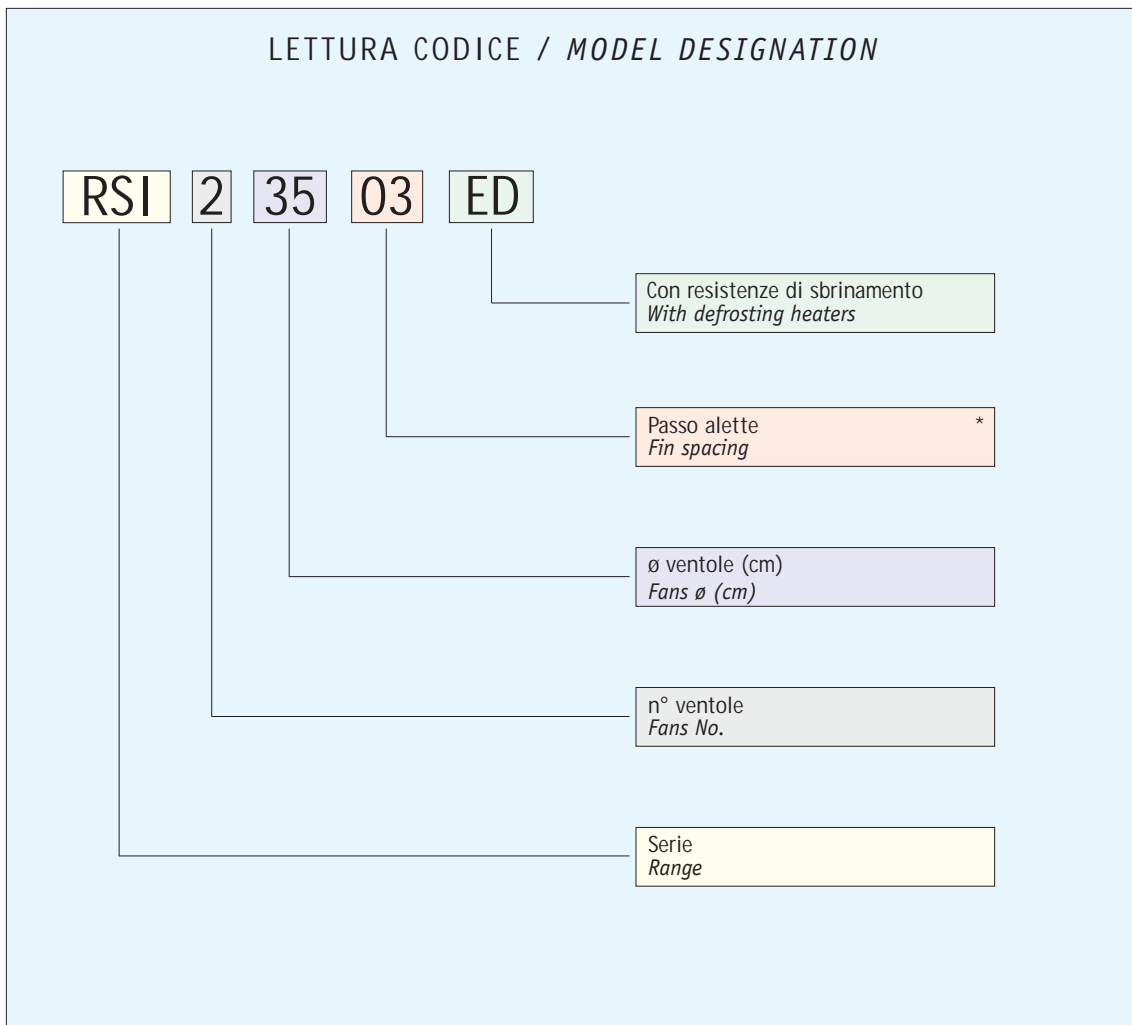
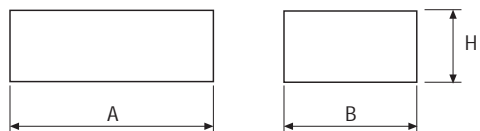

(*) Per i modelli con ventola 250mm il passo alette non viene indicato nel codice perché sempre uguale per tutti i modelli (=5,3mm)
For models having 250mm Ø fan, the fin spacing is not mentioned in the code as it is the same for all models (=5,3mm)

RIVACOLD s.r.l.

Costruzione Gruppi Frigoriferi e Accessori

Via Sicilia, 7 - 61020 Montecchio PU - Italy

Tel. +39.0721.919911 - Fax +39.0721.490015

www.rivacold.com / info@rivacold.com



A Member of **RIVACOLD GROUP** 